

PRODUCT NUMBER  
SEE TABLE

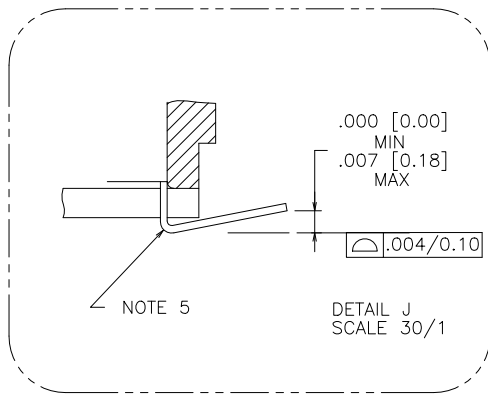
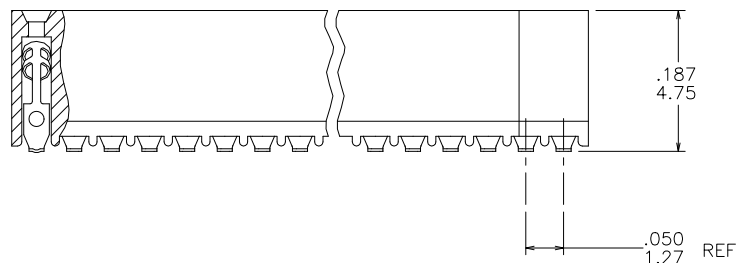
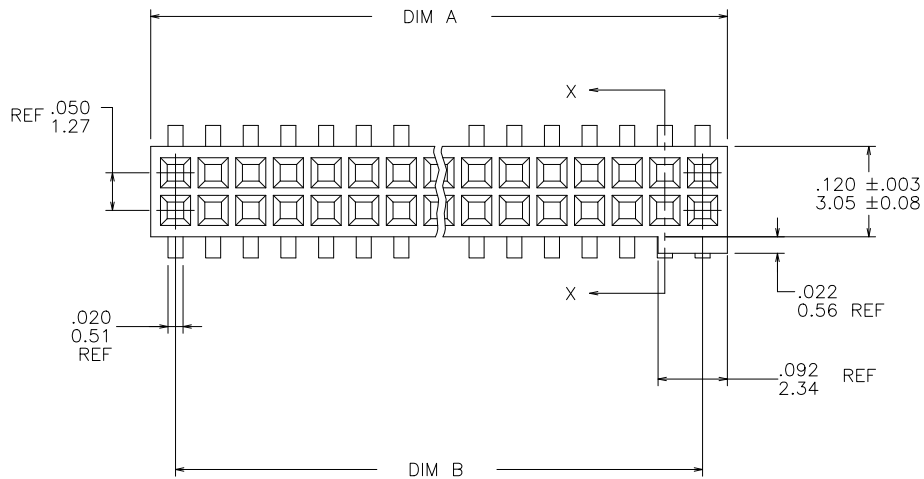

mat'l. code				surface		tolerance		projection		product family	
-				ISO 1302 ✓		ISO 406 ISO 1101				RIBCAGE	
ltr	ecn no	dr	date	tolerances unless otherwise specified						title	
U	V11874	CRG	08/22/01	angles	linear	.XX±.01/0.3		INCH/MM		.050 CC VERT. C.C. ASS'Y. SUR. MOUNT-POL.	
V	M05-0123	MHT	06/06/05			.xxx±.005/0.13					
W	M06-0225	ERE	06/12/06	0°±2°		.xxxx±.0020/0.051		scale 4:1			
X	M06-0370	MHT	09/26/06	dr	D. SHEAFFER	12/6/88				dwg no	
Y	M08-0053	MHT	02/27/08	engr	J. OSWALD	12/6/88				sheet 1 of 3 size	
AA	M09-0058	CMR	4/06/09	chr	J. OSWALD	12/6/88				87022 A3	
AB	ELX-N-010200	YO	02/07/12	appd	J. OSWALD	12/6/88				type Product Customer Drawing	
sheet	revision	AB	AB	AB							
index	sheet	1	2	3							

PRODUCT NO. NOTE 9	SIZE	DIM A	DIM B	SPECIAL PACKAGING	TAPE WIDTH PITCH	PCS. PER REEL
87022-605	2 X 5	.266/6.76	.200/5.08	NOTE 7	24mm 12mm	750
-610	2 X 10	.516/13.11	.450/11.43	NOTE 7	24mm 12mm	750
-615	2 X 15	.766/19.46	.700/17.78	NOTE 7	44mm 12mm	500
-620	2 X 20	1.016/25.81	.950/24.13	NOTE 7	44mm 12mm	500
-625	2 X 25	1.266/32.16	1.200/30.48	NOTE 7	44mm 12mm	500
-630	2 X 30	1.516/38.51	1.450/36.83	NO	—	—
-635	2 X 35	1.766/44.86	1.700/43.18	NO	—	—
-640	2 X 40	2.016/51.21	1.950/49.53	NO	—	—
-645	2 X 45	2.266/57.56	2.200/55.88	NO	—	—
87022-650	2 X 50	2.516/63.91	2.450/63.23	NO	—	—
87022-625 MIL.	2 X 25	1.266/32.16	1.200/30.48	NO	—	—

NOTE 6

NOTES :

- HOUSING MATERIAL :  
LCP GLASS FILLED . FLAME RETARDANT PER UL94V-0.  
COLOR : NATURAL
- TERMINAL MATERIAL : BeCu
- TERMINAL PLATING :  
30u"/.76u MIN HARD GOLD OR GXT OVER Ni ON CONTACT ZONES.  
100u"/2.54u MIN Sn. OVER Ni IN SOLDERING ZONES.  
OTHERWISE GOLD FLASH OR UNPLATED. MATTE TIN FINISH  
AT SOLDERING ZONE.
- APPLICATION INFORMATION:
  - RECOMMENDED MOUNTING PAD PATTERN IS  
SHOWN IN FIGURE "A".
  - MATING PINS TO BE .0176/0.447 TO .0181/0.459 DIA.
  - MATING PIN TIPS TO BE IN TRUE POSITION TO MATING  
GRID WITHIN .008/0.20 DIA.
  - SUGGESTED MATING PIN LENGTH .130/3.30  
±.010/0.25.
- LEAD TIPS TO BE ABOVE HEEL, UP TO .007/0.18 MAX.  
COPLANARITY TO BE MEASURED AT LOWEST POINT (HEEL).
- SOLDERTAIL SHALL BE FINISHED IN ACCORDANCE WITH MIL-STD-1276.  
HOT SOLDER DIP (FINISH 51) OR FUSED (REFLOWED) TIN LEAD PLATE  
(FINISH 34). 100u"/2.54u MIN.
- ADD "TR" TO END OF DASH NUMBER FOR TAPE AND REEL PACKAGING  
WITH CAP. TOOLED ONLY FOR NOTED CONNECTORS.
- ADD "CT" TO END OF DASH NUMBER FOR CONNECTOR WITH  
VACUUM CAP IN TUBE.
- ADD "LF" SUFFIX AT THE END OF PART NUMBER FOR LEAD FREE OPTION.
- THIS PRODUCT MEETS EUROPEAN UNION DIRECTIVES AND OTHER  
COUNTRY REGULATION AS DESCRIBED IN GS-22-008.
- THE HOUSING WILL WITHSTAND EXPOSURE TO 260°C PEAK TEMPERATURE  
FOR 20 SECONDS IN A CONVECTION, INFRA-RED OR VAPOR PHASE REFLOW  
OVEN. SEE APPLICATION NOTES/PROCEDURES IF THEY ARE AVAILABLE.
- PRODUCT SPEC PER BUS-12-087.

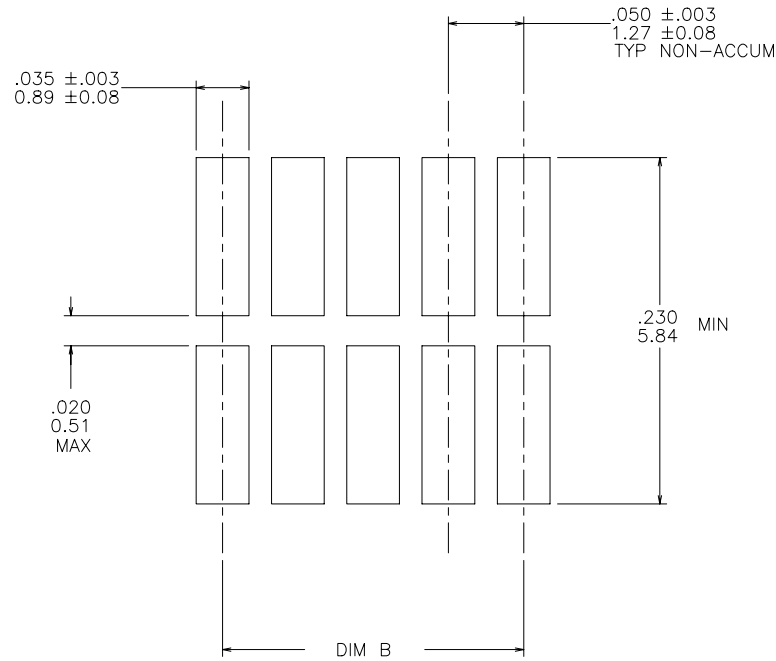
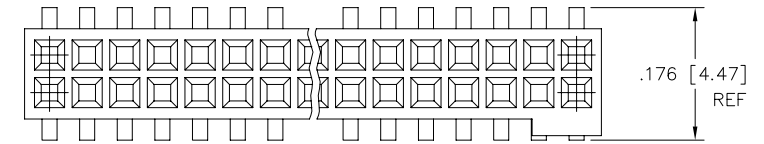

FIGURE "A"  
RECOMMENDED PCB  
MOUNTING PAD PATTERN

mat'l. code		surface		tolerance		projection		product family	
-		ISO 1302 ✓		ISO 406 ISO 1101				RIBCAGE	
ltr	ecn	no	dr	date		tolerances unless otherwise specified		title	
AB						angles	linear	.050 CC VERT. C.C. ASS'Y. SUR. MOUNT-POL.	
						0°±2'	.xx±.01/0.3 .xxx±.005/0.13 .xxxx±.0020/0.051	INCH/MM scale 4:1	
			dr	D. SHEAFFER		12/6/88		dwg no	
			engr	J. OSWALD		12/6/88		sheet 2 of 3 size	
			chr	J. OSWALD		12/6/88		87022 A3	
			appd	J. OSWALD		12/6/88		type Product Customer Drawing	
sheet	revision								
index	sheet								

PRODUCT NUMBER  
SEE TABLE

REFERENCE ONLY

TAPE WIDTH'S 32mm AND ABOVE HAS BOTH FEED TRACKS,  
BELOW 32mm HAS TOP FEED TRACK ONLY.

UNREELING  
DIRECTION

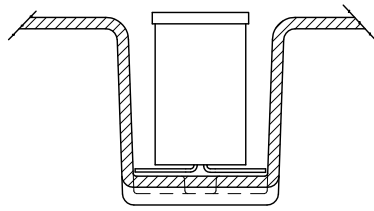
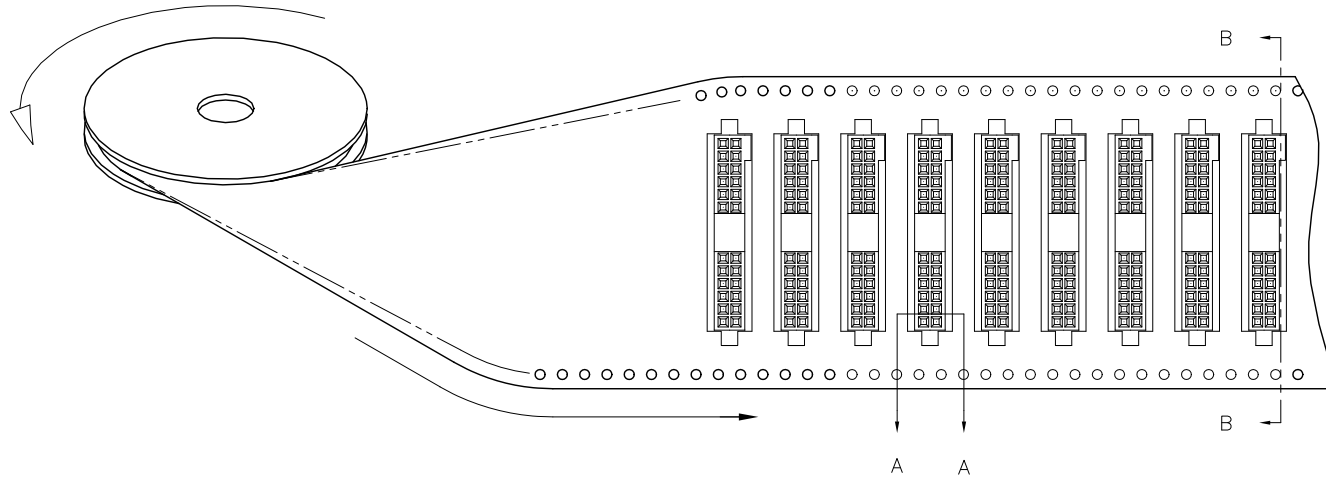

SECTION A-A

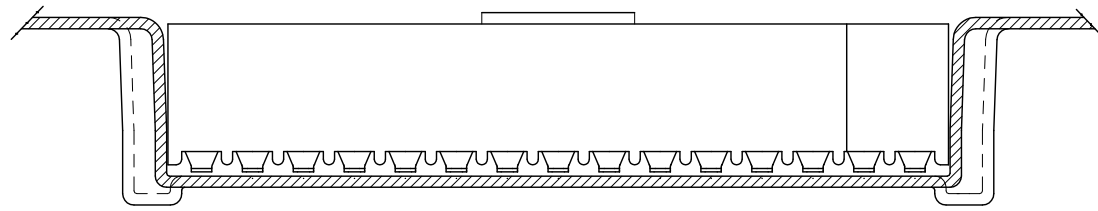

SECTION B-B

mat'l. code		surface		tolerance		projection		product family	
-		ISO 1302 ✓		ISO 406 ISO 1101				RIBCAGE	
ltr	ecn	no	dr	date		tolerances unless otherwise specified		title	
AB						angles	linear	.XX±.01/0.3 .xxx±.005/0.13 .xxx±.0020/0.051	
						0°±2'		INCH/MM	
						dr	D. SHEAFFER	12/6/88	scale 4:1
						enr	J. OSWALD	12/6/88	
						chr	J. OSWALD	12/6/88	
						appd	J. OSWALD	12/6/88	
sheet index		revision sheet						.050 CC VERT. C.C. ASS'Y. SUR. MOUNT-POL. dwg no 87022 sheet 3 of 3 size A3 type Product Customer Drawing	