

1

2

3

4

REV.	DESCRIPTION	DATE	DESIGNED
△	Corrected of mating part configuration.	APR.10.2001	M.MORITA

A

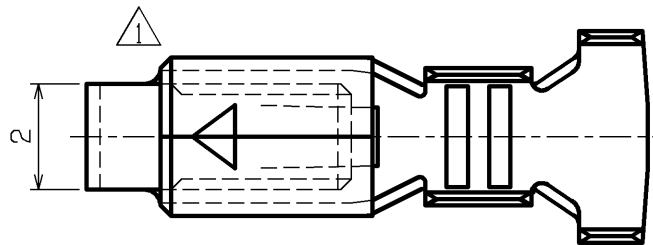

B

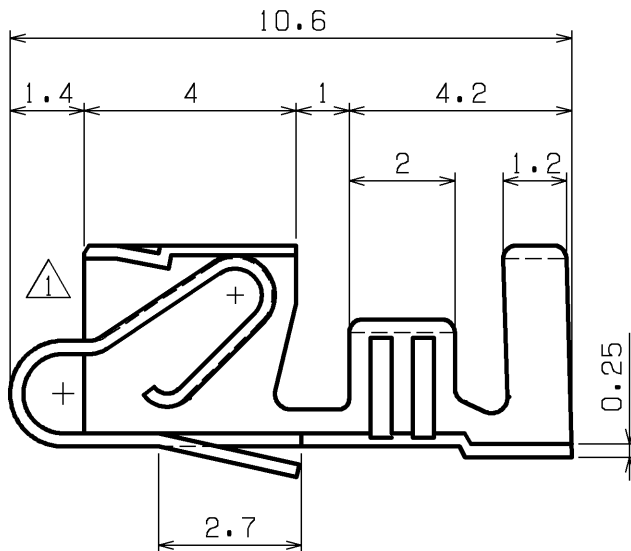

C

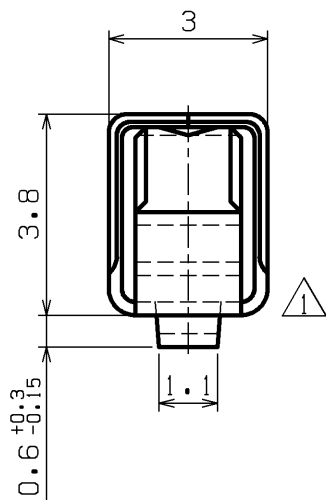

D

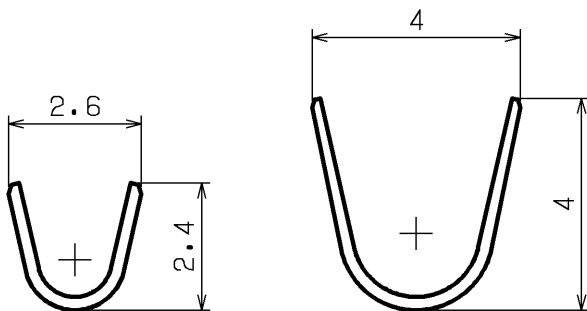

NOTE

1. Unless otherwise specified, tolerances are;
 $0 < L \leq 5.0 : \pm 0.3$, $5.0 < L : \pm 0.4$

WIRE BARREL

INSULATION BARREL

E

CONTACT		BRASS		TIN-PLATED		t0.25	
No.	PART NAME		MATERIAL		SURFACE FINISH		REMARKS
SIZE	UNIT	SCALE	PROJECTION	DATE	CUSTOMER		
A4	METRIC	7:1		MAR. 6.1997			
APPROVED	CHECKED	DESIGNED	DRAWN	SERIES NAME	VH CONNECTOR		
S.K		M.M	M.T	PART No.	SVH-21T-1.1		
JST J.S.T.MFG.CO., LTD				DRAWING No.	KRD-9430-2	R1	

F